

HDP 146 High pressure, high flow pump



Compact design

- Optimum space utilisation
- Integral reduction gear

Adaptability provides installation options

- Horizontal or vertical models
- Reversible pump head
- Central or side suction connection
- Discharge connections on both sides
- Left or right hand drive shaft
- Operates at any angle

Water end: suitable for recycled water

Less wear due to :-

- High grade solid ceramic plungers
- Wear resistant valve seats
- Low flow velocity over suction and discharge valves
- Packing seal sets within rust resistant stainless steel sleeves
- Slow plunger speed

Drive end

- Hammelmann standard industrial drive end specifically designed for continuous duty
- Pressurised oil lubrication system
- High quality spheroidal cast iron housing
- Clockwise or anticlockwise rotation

Easy servicing

- Reversible valve seats
- Suction and discharge valves use identical components
- Maintenance possible without removal of suction and pressure lines
- All service access front/above
- Fixed valve housing accessible via light weight cover plates

Environmentally friendly

- Quiet drive end due to twin helical gears
- Piston rods hermetically sealed by the NBR bellows, no oil leakage

HAMMELMANN

Technical data HDP 146

- Rod force: 90 kN
- Stroke: 55 mm
- Mean piston speed at n_2
440 1/min = 0,81 m/sec
525 1/min = 0,96 m/sec
580 1/min = 1,06 m/sec

[l/min]	Pressure [bar]	Power required [kW]	Piston \varnothing	n_1 [r.p.m.]	n_2 [r.p.m.]
270	230	113	70	1250/1500/1800	440
325	230	135	70	1500/1800/2150	525
357	210	135	70	1650	580
309	200	113	75	1250/1500/1800	440
370	200	135	75	1500/1800/2150	525
407	180	135	75	1650	580
352	175	113	80	1250/1500/1800	440
420	175	135	80	1500/1800/2150	525
462	160	135	80	1650	580

Technical details

Design	Horizontal, vertical, 3 cylinder
Plungers	Solid ceramic
Plunger sealing	Triple packing rings
Crank section sealing	Bellows
Valves	With ancillary sealing for recycled water
Valves	Reversible
Crank section lubrication	Pressurised circulating
Crankshaft bearings	2 x roller
Drive shaft	Right or left

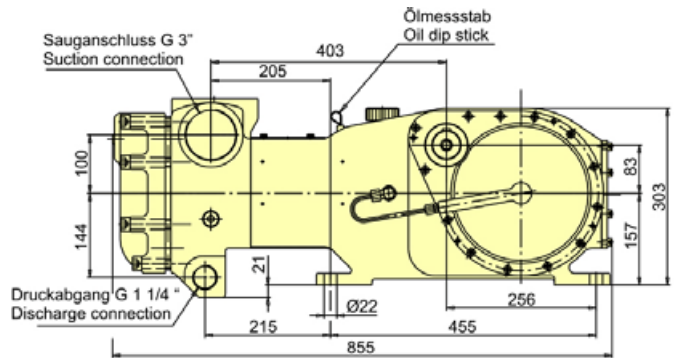

Installation data

Weight	Approx. 350 kg
Mounting points	4 x M20
Mounting hole pattern	
HDP 146 horizontal	454 x 280 mm
HDP 146 vertical	344 x 304 mm
Drive shaft	50 mm dia. x 94 mm
Shaft key	DIN 6885 – A
Permissible lateral force	12 kN
Discharge connection	G 1 1/4" female
Suction connection	100 mm i/d, PN6 DIN 2 x 3 "

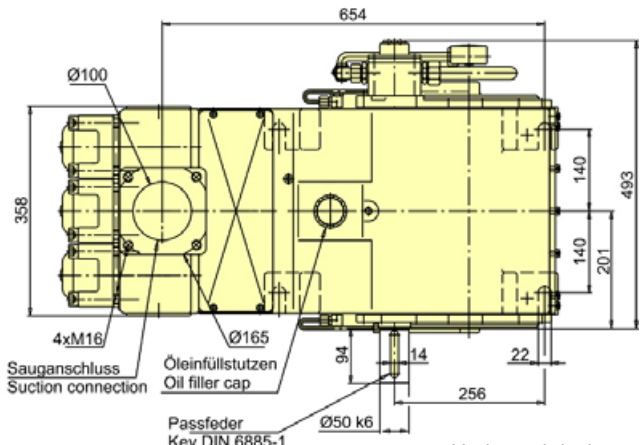

Horizontal design

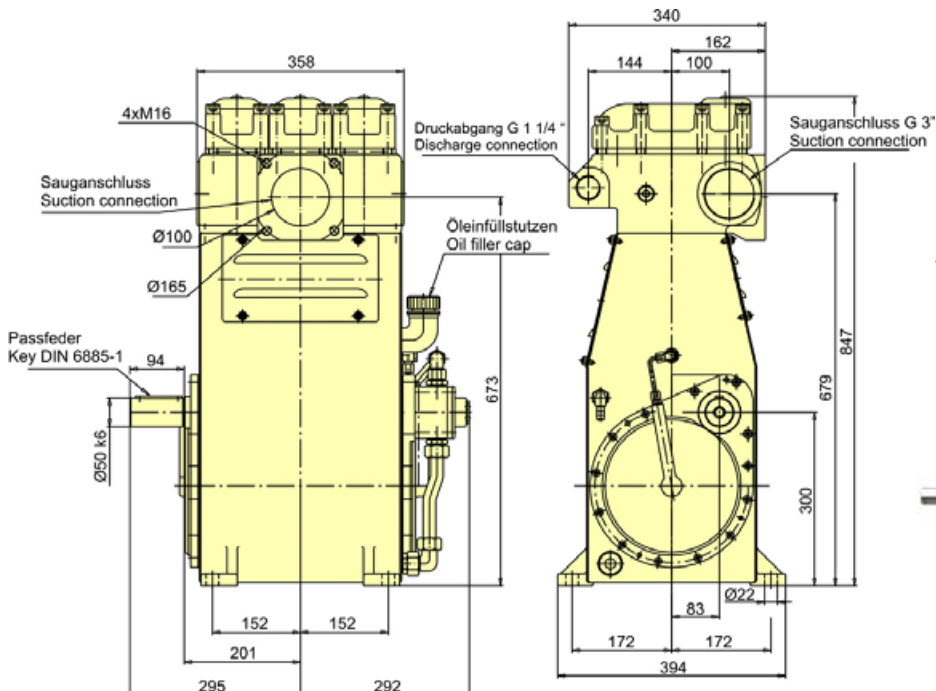

Vertical design



04/05 © Copyright Hammelmann Maschinenfabrik GmbH Oelde, Germany. Subject to modification.